

GAZELLE®

GH2870 Rotary Hammer User Manual





ORIGINAL INSTRUCTIONS

Before using this Gazelle Rotary Hammer, please carefully read through these **HANDLING**

INSTRUCTIONS

Ensure that you know how the machine works, and how it should be operated. Maintain the machine in accordance with the instructions, and make certain that the machine work correctly, please store this instruction and other enclosed documents with the machine together.



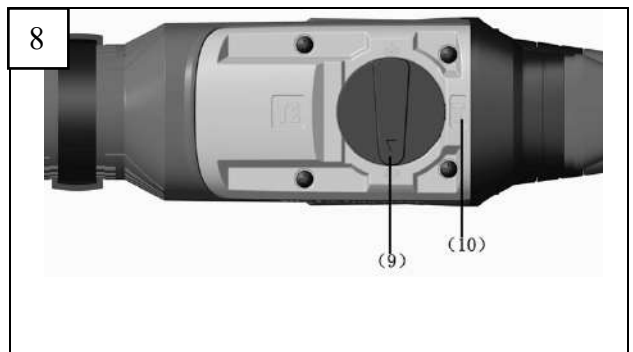
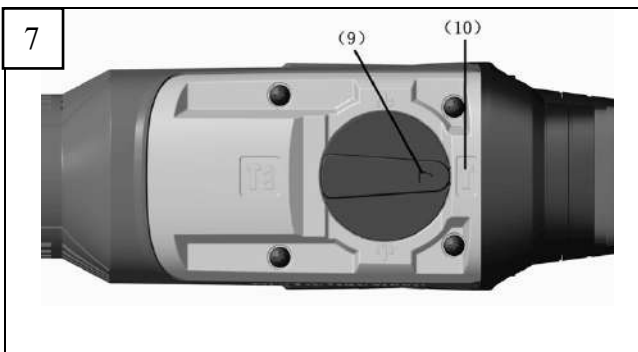
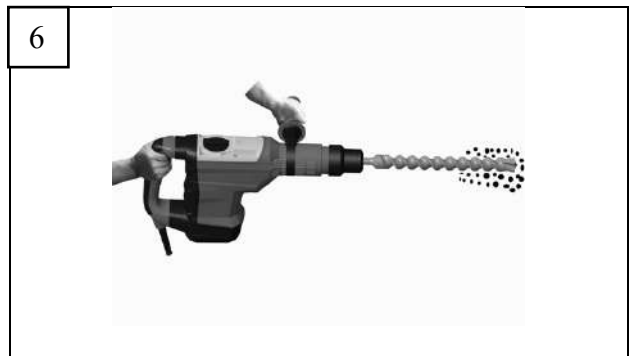
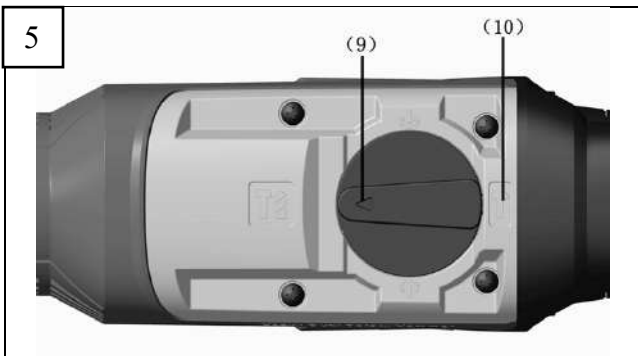
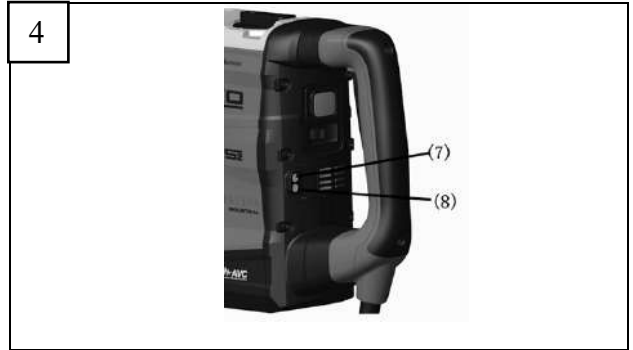
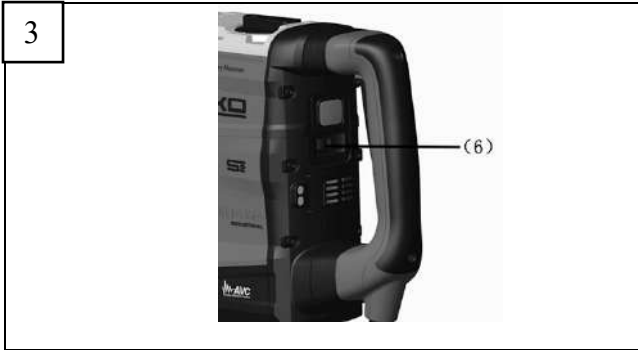
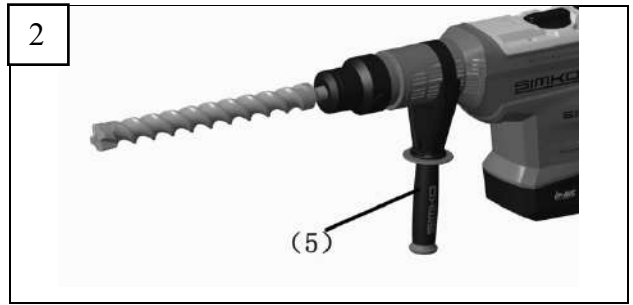
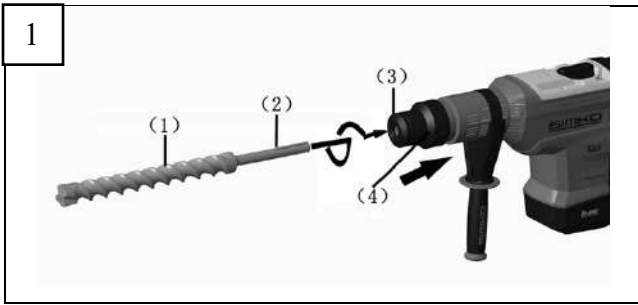

1	Drill bit
2	Part of SDS max shank
3	Hammer rod protector
4	Flex Sheath
5	Auxiliary handle
6	Speed Adjuster Knob
7	Power -ON Indicator
8	Service Indicator
9	Function Knob
10	Cover

Contents

General Power Tool Safety Warnings
 Special requirements for rotary hammer
 Safety Instructions
 Applications
 Technical Data
 Accessories
 Prior to operation
 Assembly
 Operation
 Maintenance And Inspection

General Power Tool Safety Warnings

⚠️ WARNING Read all safety warnings and all instructions. Failure to follow the warnings and instructions may result in electric shock, fire and/or serious injury.

Save all warnings and instructions for future reference.

The term "power tool" in the warnings refers to your mains-operated (corded) power tool.

1. Work area safety

- a. **Keep work area clean and well lit.** Cluttered or dark areas invite accidents.
- b. **Do not operate power tools in explosive atmospheres, such as in the presence of flammable liquids, gases or dust.** Power tools create sparks which may ignite the dust or fumes.
- c. **Keep children and bystanders away while operating a power tool.** Distractions can cause you to lose control.

2. Electrical safety

- a. **Power tool plugs must match the outlet. Never modify the plug in any way. Do not use any adapter plugs with earthed (grounded) power tools.** Unmodified plugs and matching outlets will reduce risk of electric shock.
- b. **Avoid body contact with earthed or grounded surfaces such as pipes, radiators, ranges and refrigerators.** There is an increased risk of electric shock if your body is earthed or grounded.
- c. **Do not expose power tools to rain or wet conditions.** Water entering a power tool will increase the risk of electric shock.
- d. **Do not abuse the cord. Never use the cord for carrying, pulling or unplugging the power tool. Keep cord away from heat, oil, sharp edges or moving parts.** Damaged or entangled cords increase the risk of electric shock.
- e. **When operating a power tool outdoors, use an extension cord suitable for outdoor use.** Use of a cord suitable for outdoor use reduces the risk of electric shock.
- f. **If operating a power tool in a damp location is unavoidable, use a residual current device(RCD) protected supply.** Use of an RCD reduces the risk of electric shock.

3. Personal safety

- a. **Stay alert, watch what you are doing and use common sense when operating a power tool. Do not use a power tool while you are tired or under the influence of drugs, alcohol or medication.** A moment of inattention while operating power tools may result in serious personal injury.
- b. **Use safety equipment. Always wear eye protection.** Safety equipment such as dust mask, non-skid safety shoes, hard hat, or hearing protection used for appropriate conditions will reduce personal injuries.
- c. **Avoid accidental starting. Ensure the switch is in the off position before plugging in.** Carrying power tools with your finger on the switch or plugging in power tools that have the switch on invites accidents.
- d. **Remove any adjusting key or wrench before turning the power tool on.** A wrench or a key left attached to a rotating part of the power tool may result in personal injury.
- e. **Do not overreach. Keep proper footing and balance at all times.** This enables better control of the power tool in unexpected situations.
- f. **Dress properly. Do not wear loose clothing or jewellery. Keep your hair, clothing and**

gloves away from moving parts. *Loose clothes, jewellery or long hair can be caught in moving parts.*

- g. If devices are provided for the connection of dust extraction and collection facilities, ensure these are connected and properly used.** *Use of dust collection can reduce dust-related hazards.*

4. Power tool use and care

- a. Do not force the power tool. Use the correct power tool for your application.** *The correct power tool will do the job better and safer at the rate for which it was designed.*
- b. Do not use the power tool if the switch does not turn it on and off.** *Any power tool that cannot be controlled with the switch is dangerous and must be repaired.*
- c. Disconnect the plug from the power source before making any adjustments, changing accessories, or storing power tools.** *Such preventive safety measures reduce the risk of starting the power tool accidentally.*
- d. Store idle power tools out of the reach of children and do not allow persons unfamiliar with the power tool or these instructions to operate the power tool.** *Power tools are dangerous in the hands of untrained users.*
- e. Maintain power tools. Check for misalignment or binding of moving parts, breakage of parts and any other condition that may affect the power tool's operation. If damaged, have the power tool repaired before use.** *Many accidents are caused by poorly maintained power tools.*
- f. Keep cutting tools sharp and clean.** *Properly maintained cutting tools with sharp cutting edges are less likely to bind and are easier to control.*
- g. Use the power tool, accessories and tool bits etc. in accordance with these instructions, taking into account the working conditions and the work to be performed.** *Use of the power tool for operations different from those intended could result in a hazardous situation.*

5. Service

- a. Have your power tool serviced by a qualified repair person using only identical replacement parts.** *This will ensure that the safety of the power tool is maintained.*

Special requirements for rotary hammer

- 1. Wear ear protectors.** *Exposure to noise can cause hearing loss.*
- 2. Use auxiliary handles, if supplied with the tool.** *Loss of control can cause personal injury.*
- 3. Hold Power tool by insulated gripping surfaces, when performing an operation where the cutting accessory may contact hidden wiring or its own cord.** *Cutting accessory contacting a "live" wire may make exposed metal parts of the power tool "live" and could give the operator an electric shock.*
- 4. Wear a dust mask.** *Do not inhale the harmful dusts generated in drilling or chiseling operation. The dust can endanger the health of yourself and bystanders.*
- 5. Before beginning work, check the working area (e.g. with a metal detector) to ensure that no concealed electric cables or gas and water pipes are present.** *Contact with electric lines can lead to fire and electric shock. Damaging a gas line can lead to explosion. Penetrating a water line causes property damage or may cause an electric shock.*

6. If the supply cord of this power tool is damaged, it must be replaced by a specially prepared cord available through the service organization.
7. Do not touch the bit during or immediately after operation. The bit becomes very hot during operation and could cause serious burns.
8. **Do not use the power tool with a damaged cord. Do not touch the damaged cord and pull the plug from the outlet when the cord is damaged while working.** Damaged cords increase the risk of an electric shock.
9. **If the supply cord is damaged, it must be replaced by the manufacturer, its service agent or similarly qualified persons in order to avoid a hazard.**
10. **Warning:** Reduce the working time to avoid risks related with too much vibration.







Residual risks

Even when the power tool is used as prescribed it is not possible to eliminate all residual risk factors. The following hazards may arise in connection with the power tool's construction and design:

1. Damage to lungs if an effective dust mask is not worn.
2. Damage to hearing if effective hearing protection is not worn.
3. Damages to health resulting from vibration emission if the power tool is being used over longer period of time or not adequately managed and properly maintained.

WARNING! This power tool produces an electromagnetic field during operation. This field may under some circumstances interfere with active or passive medical implants. To reduce the risk of serious or fatal injury, we recommend persons with medical implants to consult their physician and the medical implant manufacturer before operating this machine.

Safety instructions

	Double insulation		Read the operating instructions before use.
	General Warning		Indicate electrical shock hazard.
	Wear ear and eye protection.		Immediately unplug the plug from the main electricity in the case that the cord gets damage and during maintenance.

Application

- Drilling holes in concrete
- Crushing concrete, chipping, digging, and squaring (by applying optional accessories)

Technical Data

Model No	GH2870
ID No.	01.02.0060
Rated Voltage	220-240V~
Frequency	50Hz
Rated power	1500W
No load speed	150-305 min ⁻¹
Impact rate	1380-2760min ⁻¹
Impact energy	2-15J
Tool holder type	SDS-Max
Max. drilling Capacity	Drill bit: Φ 52mm Core bit: Φ 160mm
Optimum drilling diameter in concrete	Φ 25- Φ 45mm
Weight (without cord)	9.1kg
Protection class	II
Vibration	
"Hammer drilling concrete" $a_{h,HD}$	11.897 m/s ² K=1.5m/s ²
"Chiselling" $a_{h,Cheq}$	8.453 m/s ² K=1.5m/s ²
Noise:	
Rotary hammer mode: L _{PA}	86.6 m/s ² K=1.5m/s ²
Chiselling mode: L _{PA}	98.0m/s ² K=1.5m/s ²

*Note type designation on the device, differences might depend on area.



Wear hearing protection while operating the power tool.

The declared vibration total value has been measured in accordance with a standard test method and may be used for comparing one tool with another.

The declared vibration total value may also be used in a preliminary assessment of exposure.

Warning !

The vibration emission during actual use of the power tool can differ from the declared total value depending on the ways in which the tool is used.

There is the need to identify safety measures to protect the operator that are based on an estimation of exposure in the actual conditions of use (taking account of all parts of the operating cycle such as the times when the tool is switched off and when it is running idle in addition to the trigger time).

Standard Accessories

1 - Carbon Brush

1 - Auxiliary handle

Standard accessories are subject to change without notice.

Optional Accessories (Sold Separately)

1. Through-hole drilling (Rotation + Hammering)



2. Tine Chisel (Hammering) :18*400mm(SDS max)

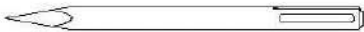

3. Flat Chisel (Hammering) :18*400mm (SDS max)



4. Big Flat Chisel (Hammering) :18*400mm (SDS max)



5. Goose Chisel (Hammering) :18*400mm (SDS max)



6. Surface Roughing (Hammering)

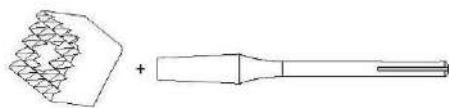

(1) Bushing Tool + (2) Shank

7. Tamping (Hammering)

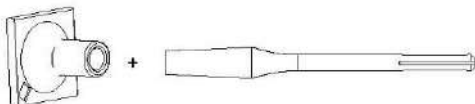

(1) Rammer + (2) Shank (150 x 150 mm)

Optional accessories are subject to change without notice.

Prior To Operation



Read the ENTIRE IMPORTANT SAFETY INFORMATION section at the beginning of this manual including all text under subheadings therein before set up use of this products.

1. Power source check

Ensure that the power source to be utilized conforms to the power requirements specified on the product nameplate.

2. Switch status check

Ensure that the power switch is in the OFF position. If the plug is connected to a power receptacle while the power switch is in the ON position, the power tool will start operating immediately, which could cause a serious accident.

3. Extension cord

When the work area is removed from the power source, use an extension cord of sufficient thickness and rated capacity. The extension cord should be kept as short as practicable.

Assembly

1. Install and Removing the SDS-max bit (Fig.1)

CAUTION:

To prevent accidents, make sure to turn the switch off and disconnect to the plug from the power receptacle.

Warning:

Always wear gloves when changing accessories. The exposed may become extremely hot during operation.

NOTE:

When using tools such as Tine chisel, drill bits, etc., make sure to use the genuine parts designated by our company.

- a. Clean the bit shank and apply grease before inserting the bit.
- b. Insert the bit into the tool. Turn the bit with slight pressure, you can feel a spot where there is a hitch. At that spot, push it in until engages in.
- c. Pull the bit to make sure it is locked completely.
- d. To remove the bit, fully pull the flex sheath in the direction of the arrow and pull out the tool.

2. Auxiliary handle (Fig.2)

Operate your power tool only with the auxiliary handle .

The auxiliary handle can be set to any position for a secure and low-fatigue working posture.

Turn the bottom part of the auxiliary handle in counterclockwise direction and swivel the auxiliary handle to the desired position. Then retighten the bottom part of the auxiliary handle by turning in clockwise direction.

Pay attention that the band of the auxiliary handle is positioned on the front housing as intended for.

3. Regulating the number of rotations and hammering (Fig. 3)

This Rotary Hammer is equipped with a built-in electronic control circuit that can adjust and regulate the number of rotations and times of hammering. This Rotary Hammer can be used by adjusting the speed adjuster knob, depending upon the contents of operation, such as boring holes into fragile materials, chipping, centering, etc.

The scale '1' of the speed adjuster knob is designed for a minimum speed with the number of 150 rotations per minute and 1380 times of blow per minute. The scale '6' is designed for a maximum speed with the number of 305 rotations per minute and 2760 times of blow per minute.

CAUTION:

Do not adjust the speed adjuster knob during operation. Doing so can result in injury because the Rotary Hammer must be held by only one hand, disabling the steady control of the Rotary Hammer.

4. Indicator LEDS (Fig. 4)

The green power-ON indicator LED lights up when the tool is plugged. If indicator led does not light up, the mains cord or the controller may be defective. The red service indicator LED lights up when the carbon brushes are worn out to indicate that the tool needs servicing.

Operation

CAUTION:

To prevent accidents, make sure to turn the switch off and disconnect the plug from the receptacle when the drill bits and other various parts are installed or removed. The power switch should also be turned off during a work break and after work.

1. Switch operation

Switching On/Off in "rotation + hammering"

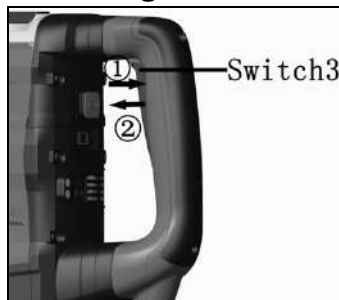

Switch on	Press the switch 3 towards ① direction
Switch off	Release the switch 3 towards ② direction

Switching On/Off in “hammering”

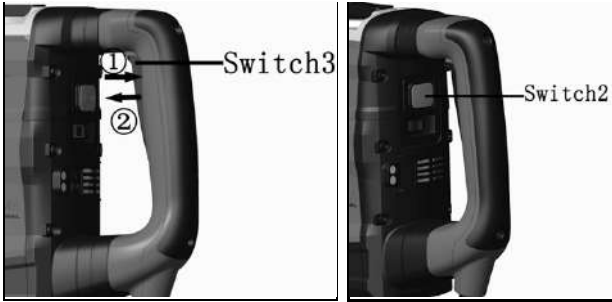

Switch on	Press the switch 3 towards ① direction
Switch off	Release the switch 3 towards ② direction
If continuous Operation, Press the switch 2 towards “I” direction, to stop from the locked Position , just press the Switch 2 towards “0” direction.	

2. When drilling at “rotation + hammering”:

If you switch the function knob during motor rotation, the tool can start to rotate abruptly, resulting in unexpected accidents. Be sure to switch the function knob when the motor is at a complete stop.

(1) Switching to “rotation + hammering”

Turn the function knob clockwise. Align ▲ of the function knob and **IT** of the cover as illustrated in **Fig.5**

(2) Mount the drill bit.

(3) Pull the trigger switch3 after applying the drill bit tip to the drilling position **Fig.6**

(4) Pushing the rotary hammer forcibly is not necessary at all. Pushing slightly so that drill dust comes out gradually is sufficient.

CAUTION: Although this machine is equipped with a safety clutch, if the drill bit becomes bound in concrete or other material, the resultant stoppage of the drill bit could cause the machine body to turn in reaction. Ensure that the main handle and side handle are gripped firmly during operation.

3. When chipping and chiseling at “hammering”:

CAUTION:

- If the function knob is switched during motor rotation, the tool can start to rotate abruptly, resulting in unexpected accidents. Make sure to switch the function knob when the motor is at a complete stop.
- If the tine chisel or flat chisel is used at the position of “rotation hammering”, the tool can start to rotate, resulting in unexpected accidents. Make sure that they are used at the position of “hammering”.

(1) Switching to “hammering”

Turn the function knob counterclockwise. Align ▲ of the function knob and **T** of the cover as illustrated in **Fig.7**

(2) When fixing working positions of flat chisel such as cold chisel, etc.,

a) Turn the function knob, Align ▲ of the function knob and **↩** of the cover as illustrated in **Fig.8**.

b) Fix the flat chisel to the desired working direction in **Fig. 9**.

c) Switch the selector lever to “hammering” according to the procedures mentioned in the above item (1) and secure the position of the tool.

5. Warming up (Fig.10)

The grease lubrication system in this unit may require warming up in cold regions. Position the end of the bit so makes contact with the concrete, turn on the switch and perform the warming up operation. Make sure that a hitting sound is produced and then use the unit.

CAUTION:

When the warming up operation is performed, hold the side handle and the main body securely with both hands to maintain a secure grip and be careful not to twist your body by the jammed drill bit.

Maintenance And Inspection



Before do any maintenance and inspection, ensure unplug the plug.

1. Inspecting the tool

Use a dull accessory, such as bull point, cutter, etc., will cause motor malfunction and efficiency degraded. Replace with a new one when your accessory is abased.

2. Inspecting the mounting screws

Regularly inspect all mounting screws and ensure that they are properly tightened. Should any of the screws be loose, retighten them immediately. Failure to do so could result in serious hazard.

3. Maintenance of the motor

The motor is the heart of the machine, please avoid any damage to the winding, or any water and oil to wet it.

4. Inspecting the carbon brushes

The Motor employs carbon brushes which are consumable parts. When they become worn to or near the “wear limit”, it could result in motor trouble. The red service indicator LED lights up when the carbon brushes are worn out to indicate that the tool needs servicing. The power tool must then be sent to an after-sales service agent.

When you have to replacement the carbon brushes by yourself, please following the order:

- (1) Loosen the two set screws and remove the fan cover.
- (2) Remove the helical spring and carbon brushes.
- (3) After replacing the carbon brushes, install the helical spring and fan cover, with securely tightening two set screws.

5. Cleaning

Clean the machine regularly with a soft cloth, preferably after each use. Solvent such as gasoline, thinner, alcohol etc.. These kind of chemical materials are not allowed to use, water or soap are recommended!

6. Protecting the Environment

Do not dispose of power tools together with household waste material!

The machine, accessories and packaging should be sorted for environmental friendly recycling.



In observance of European Directive on waste electrical and electronic equipment and its implementation in accordance with national law, electric tools that have reached the end of their life must be collected separately and returned to an environmentally compatible recycling facility.

CAUTION:

Repair, modification and inspection of Gazelle Power tools must be carried out by a Gazelle Authorized Service Center.

In the operation and maintenance of power tools, the safety regulations and standards prescribed in each country must be observed.

MODIFICATIONS:

Gazelle Power Tools are constantly being improved and modified to incorporate the latest technological advancements.

Accordingly, some parts (i.e. code numbers and/or design) may be changed without prior notice.

NOTE:

Due Gazelle's continuing program of research and development, the specifications herein are subject to change without prior notice.

INNOVATION
PERFORMANCE
SAFETY
CONFIDENCE
GAZELLE

GAZELLE

sales@gazelleindustrial.com | www.gazelleindustrial.com