

GAZELLE

GAZELLE G9802 Pipeline Air Leakage Tester

User Manual



Please read and understand the warnings and precautions listed in this instruction manual carefully before using the product. For long-term use, please keep this instruction manual safe.

Precautions

The types of warnings used in this instruction manual are defined as follows.

[Identification Explanation]



Warning: For preventing personal injury. Ignoring these warnings may result in a risk of personal injury.



Caution: For preventing damage to the instrument. Ignoring these warnings may damage the instrument or cause a decrease in its performance.



The symbols indicate precautions (including dangers). Specific precautions are drawn within the triangular boxes.



The symbols indicate prohibited items. The specific prohibited items are drawn inside the circular boxes.



The symbols represent mandatory actions. Specific details are drawn near the diagram.



Do not place the instrument in flammable gas environments. Do not use the instrument in flammable gas atmospheres; otherwise, it may cause a fire or even an explosion.



禁止拆卸 Do not disassemble or modify the instrument. Doing so may result in electric shock or fire.



Please use the instrument correctly according to the instructions in the user manual. Improper use may result in sensor damage, electric shock, or fire.



If the instrument emits any unusual odor, sound, smoke, or liquid seeps into its interior during use, immediately disconnect the power and contact the manufacturer. Otherwise, there may be a risk of electric shock, fire, and damage to the instrument.



Do not expose the instrument to rain. Doing so may cause a fire or even an explosion.



Unplug the power cord when not in use. Otherwise, there may be a risk of damage to the internal circuitry, electric shock, or fire.



Do not place the instrument in high temperature, high humidity, dusty, or direct sunlight environments. Do not expose the instrument to rain. Otherwise, internal components may be damaged or the instrument's performance may degrade.



Do not drop or subject the instrument to heavy pressure. Otherwise, it may cause malfunction or damage.



The maximum load capacity of the lifting ring is 200 kg. Otherwise, it may cause instrument malfunction or damage.

1 Product Introduction

The duct leakage tester is mainly used for testing the sealing performance of air conditioning ducts (air ducts). It can test segmented ducts and the main duct after the entire system is installed, ensuring the working efficiency of the air conditioning system and avoiding energy waste. This instrument performs tests according to relevant certification standards and can directly determine whether the duct's sealing performance is up to standard. It uses a touchscreen operation and an LCD color screen display, providing a user-friendly interface for convenient operation.

1.1 Features

- ◆ Can detect pipeline sealing under positive and negative pressure.
- ◆ Pipeline sealing is assessed according to the following standards: EN1507:2006, EN12237:2003, Eurovent 2/2, DW/143, SMACNA Standard, AABC Standard, GB50243—2003/2016.
- ◆ Wide airflow measurement range; two measuring tools ensure measurement accuracy.
- ◆ Assessment results directly determine whether the pipeline sealing is qualified.
- ◆ Real-time display of leakage, test pressure, temperature, and atmospheric pressure.
- ◆ 1000 sets of data storage, browsing, and deletion.
- ◆ 5-inch LCD touchscreen for easy operation.
- ◆ Simple structure and easy installation.

1.2 Main Specifications

model:		G9802
flow	Range	Matrix: 36~640 m ³ /h Nozzle: 4~ 36 m ³ /h
	Accuracy	±2.5% of the reading ±0.1 m ³ /h
	Resolution	0.01 m ³ /h
static pressure	Range	±2500 Pa
	Accuracy	1% ± 1 Pa of the reading
	Resolution	0.1 Pa
temperature	Range	0~60 °C
	Accuracy	±0.5°C
	Resolution	0.1 °C
Atmospheric pressure	Range	70~130kPa
	Accuracy	±2% of the reading
	Resolution	0.1kPa
powersupply	G9802-0E	100-120V,1 Phase,50/60Hz,16A
	G9802-1E	200-240V,1 Phase,50/60Hz, 10A
weight		Net weight approximately 72kg
size		54*50*120cm
Storage		1000

2 Appearance and structure

2.1 Overall structure

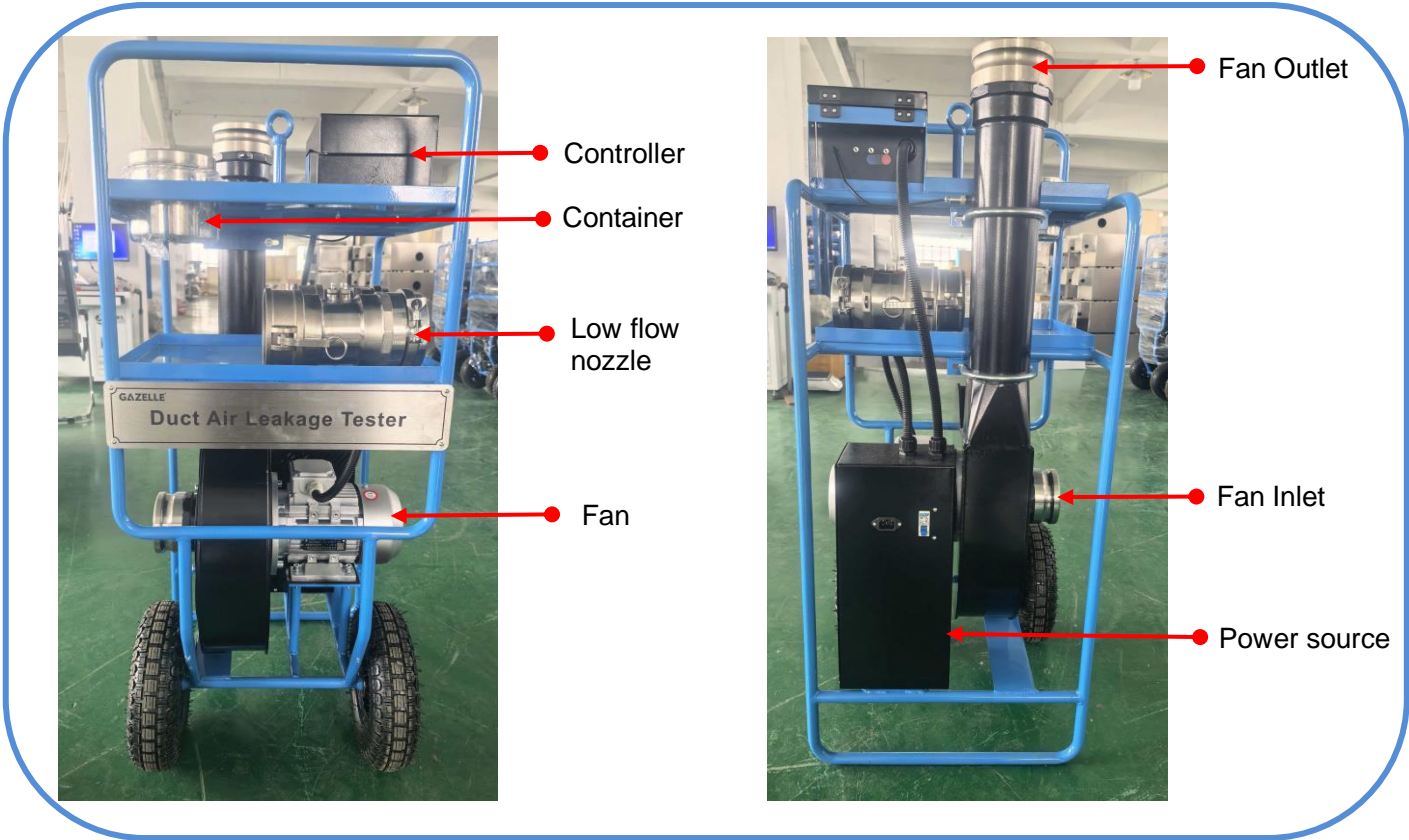

2.2 Control box structure

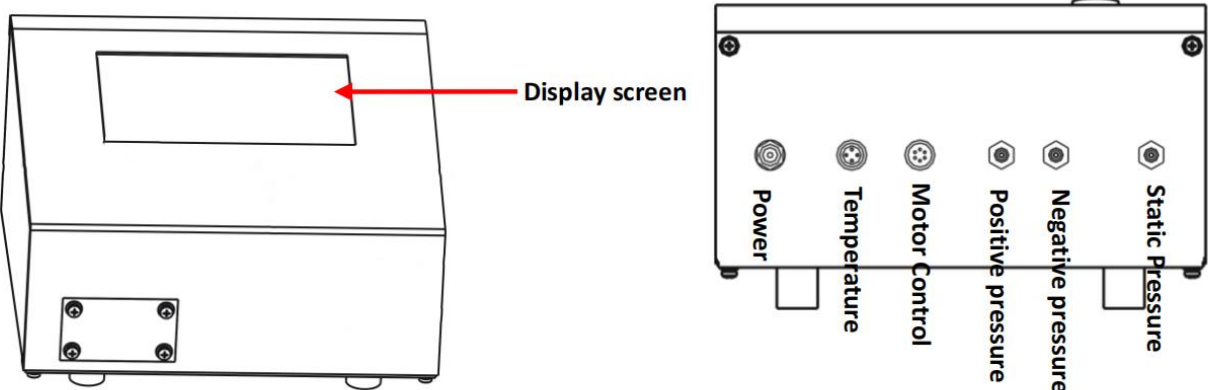

3 Instrument installation

During use, either a nozzle or a matrix tool can be selected for testing based on the range of airflow to be measured. This instrument is suitable for air conditioning duct blowing and exhaust systems. Generally, nozzle tools are used for low-flow testing, while matrix tools are used for high-flow testing.

3.1 Pipeline connection under test

Preparations before pipeline qualification:

(1) Refer to Appendix 1, Pipeline Qualification Standards, to determine the qualification standards, sealing level, and test pressure;

(2) Temporarily seal all joints of the pipeline to be tested, leaving only one joint connected to the testing machine. Calculate the surface area of the pipeline to be tested, within the input range of the testing machine;

Connect the pipe under test to the testing machine:

(1) Place the testing machine near the pipeline under test to minimize the length of the corrugated pipe and reduce pressure loss.

(2) Connect one end of the corrugated pipe assembly to the testing machine and lock it with a cam-locking connector. Connect the other end to the pipeline under test via a flange. The user should install it according to the actual condition of the pipeline under test.

(3) If there is a static pressure tap on the pipeline under test, connect the static pressure pipe to the tap. Otherwise, drill $\phi 6$ holes in the pipeline, insert the static pressure pipe into the pipeline, and seal the area around the static pressure pipe. Connect the other end of the static pressure pipe to the control box.

(4) Calculation of duct surface area: Surface area $S = (ab + bc + ca) \times 2$

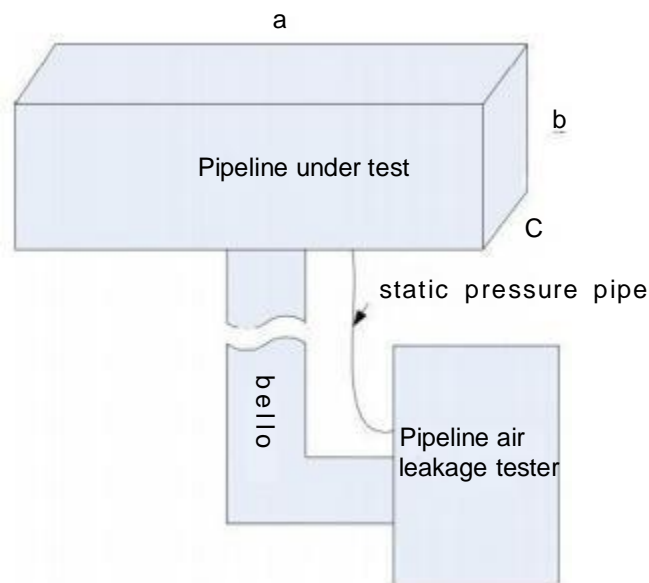

3.2 High leakage test

High leakage testing was performed using a matrix tool. The matrix tool was installed at the fan outlet, and the cam locking connector was tightened. The pressure taps on the matrix tool were connected to the airflow differential pressure interface of the control box, with the connections made according to color.

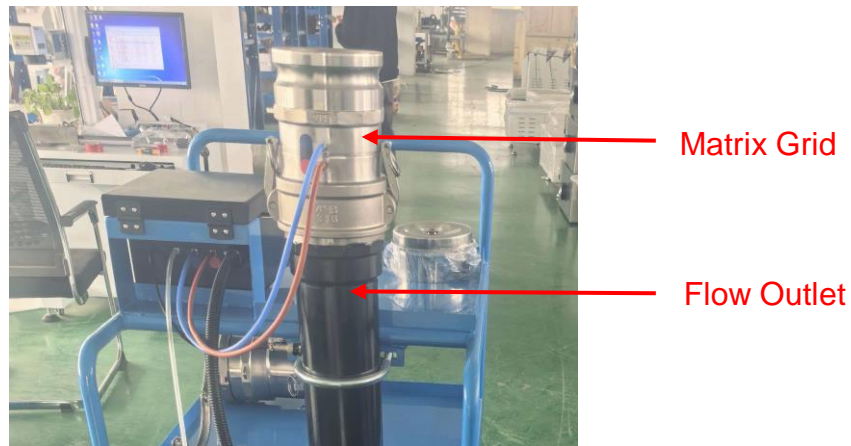

Note: When locking the cam locking joint, apply force to the cam locking arm simultaneously.

1. Positive pressure test of the pipeline: Connect the cam locking connector of the bellows to the matrix air outlet and lock it.

2. Negative pressure test of the pipeline: Connect the cam locking connector of the bellows to the fan inlet and lock it.



High flow Duct testing under positive pressure

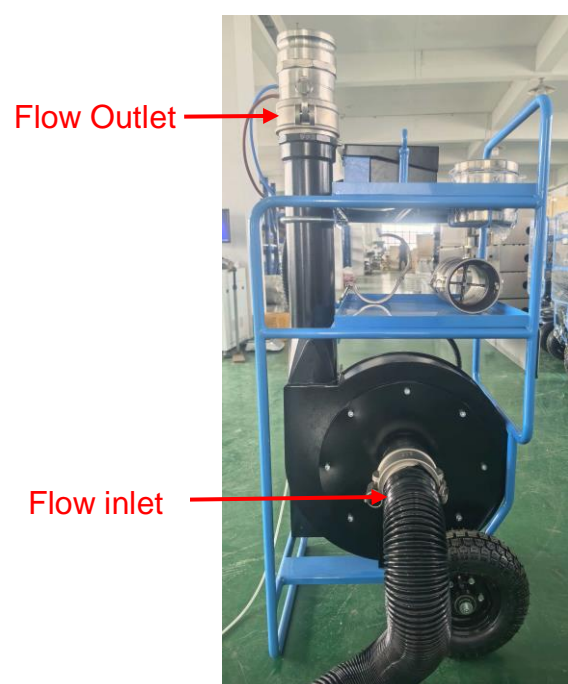

High flow Duct testing under Negative pressure

3.3 Low leakage test

The low-flow test uses a nozzle tool to install the nozzle element at the fan outlet and lock the cam locking connector. The pressure tap on the nozzle tool is connected to the airflow differential pressure interface of the control box, according to the color codin

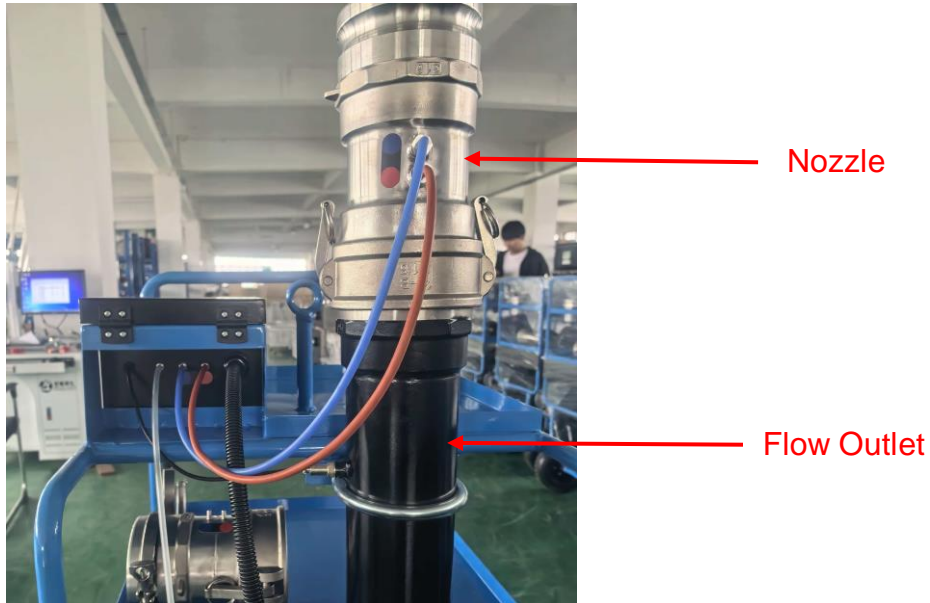

1. Positive pressure test of the pipeline: Connect the cam locking connector of the bellows to the nozzle outlet and tighten it.

2. Negative pressure test of the pipeline: Connect the cam locking connector of the bellows to the fan inlet and tighten it.

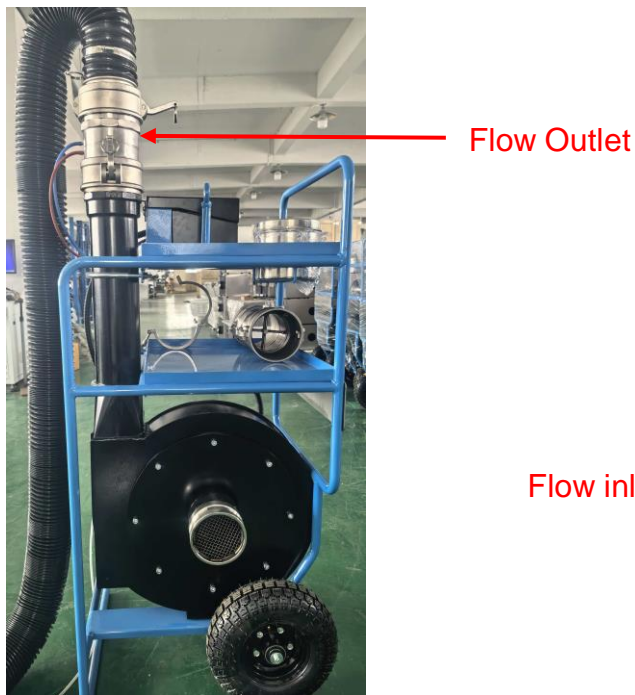

**Low-flow Duct testing
under positive pressure**

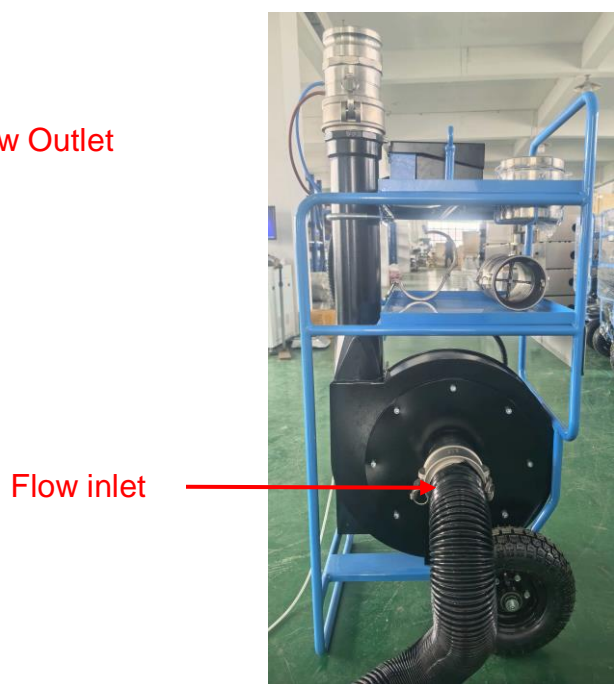

**Low-flow Duct testing
under Negative pressure**

4.How to use

4.1.Power on the instrument

1. Connect to power: This instrument is powered by AC power. Connect the power cord and turn on the power protector. Check that the connection cable at the rear of the control box is secure.

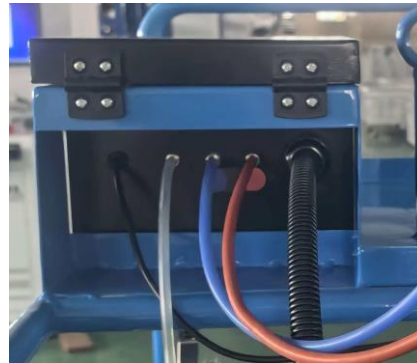

2. Control box powered on : After connecting the control box to the power supply, turn on the control switch to power on the instrument .



3. Main Interface Introduction

Authentication Test	The evaluation interface allows users to set evaluation criteria for pipe sealing, conduct tests according to relevant standards, and save the data.
General Test	The testing interface allows for the measurement of airflow, pressure, temperature, and atmospheric pressure.
Settings	In the settings interface, you can configure parameters such as date, time, test mode, and unit.
Data	The data browsing/deletion interface allows you to browse or delete data.
USB	The export interface allows you to export stored data to a USB drive.
About	Regarding the interface, this section introduces the instrument's basic performance parameters.

4.2.Identification Interface

The evaluation interface requires setting parameters such as tools, standards, sealing rating, pipe surface area, and test time to control the static pressure within the pipe. Pipe evaluation can only proceed once the static pressure meets the standard requirements. After evaluation, the results are output and can be saved or measured again.

[Click the "Identification Test" button on the main interface to enter]

4.2.1 Set test parameters

1. Select the traffic tool
2. Select test criteria
3. Select or enter the sealing grade
4. Input the pipe surface area
5. Enter the test time
6. Next steps



4.2.2 Start adjusting the fan

1. Start the fan
Click "Start"
2. Regulating fan (pipeline static pressure)
 - a. Click "Pressurize" or "Depressurize"
 - b. slide control
3. Enter the test



Note: Before starting the fan, check that the pipeline is smooth and there is no folding phenomenon!

4.2.3 Enter the test

The interface includes:

- Current result count
- Real-time value display area
- Set the parameter display area
- Results show the area
- Operation buttons



1. Click "Start" and test according to the set parameters
2. Wait for the test time to end (the result cannot be saved if it is stopped in the middle)
3. You can choose to save the test results or click "Start" to retest

The "+" and "-" in the pressure display box can also adjust the wind force (pipeline pressure)

Click the icon in the upper right corner to enter the results interface (see the results interface section for details)

4.3 General test

[Click the "Normal Test" button on the main interface to enter]

4.3.1 Set test parameters



1. Select a traffic tool
2. Click Next

4.3.2 Start adjusting the fan

1. Start adjusting the fan
2. Click "Enter the test"



4.3.3 Enter the test

The interface includes:

- Real-time value display area
- Set the parameter display area
- Results show the area
- Operation buttons



Click "Start" and test according to the set parameters

4.4 Result interface

[Click the "Results" button on the main interface to enter]

The serial number of the current display result is displayed in the upper right corner of the interface.

The parameters are displayed on the left and the result data is displayed on the right.

Click the arrow button below to switch to the previous or next result.

Click Delete to delete all results in segments.

After inserting the U disk, click "USB Export" to export to the U disk.

< 主页		结果记录	0002/0010
工具	矩阵	测试日期	2025/01/29 18:00:30
标准	GB	静压	247.6 Pa
等级	中压	漏风量	0.865259 m ³ /h
表面积	80.00 m ²	漏风率	0.892645 m ³ /h/m ²
测试时间	60 s	上限	1.254908 m ³ /h/m ²
		温度	20.4 °C
		大气压	102.7 kPa

合格

<
>
删除
USB导出

4.5 Set the interface

[Click the "Settings" button on the main interface to enter]

1. Airflow Mode:

Selectable between actual operating conditions and standard operating conditions

2. Unit Settings:

Airflow Unit

Pressure Unit

Atmospheric Pressure Unit



4.6 About

[Click the about icon in the upper left corner of the main interface to enter]



- System Settings
 - Date and time Settings
 - Language Settings
 - Restore factory Settings (Restore factory Settings restores all test standards to their original state)
- Controller information
 - View the information of this controller, such as serial number, motor type, etc.

4.7 calibration

Long press the area on the right of the title bar in the main interface, as shown in the blue box area below, and a password input box will pop up. After entering the correct password, click OK to enter the calibration interface.



Precautions

1. Please power the product within the permissible voltage range.
2. The screen of this product is made of glass; please avoid scratches or impacts.
3. Do not operate the touchscreen with sharp objects to avoid malfunctions or unresponsiveness.
4. Ensure proper ventilation and heat dissipation during installation, and avoid direct contact with heat sources.
5. Keep the product away from water. If water accidentally gets into the product, disconnect the power immediately.
6. When not in use for extended periods, disconnect the power and keep the product dry.
7. Do not disassemble or replace parts without authorization from the manufacturer.
8. This product comes with a one-year warranty; free repairs are provided for non-human-caused damage.
9. For any questions or after-sales service, please contact our customer service department.

5 Common Faults and Troubleshooting Methods

No.	Fault phenomenon	reason	Solution
1	Control box does not start	No power supply connected	Check the power supply and wiring according to Chapter 4.1.
		Internal circuit malfunction	Please contact the manufacturer.
2	The motor does not start	Power phase loss	Check the power supply
		The motor control line is not connected or has poor contact.	Connect motor control cable
		The control box is malfunctioning.	Restart the control box. If the problem persists, contact the manufacturer.
3	Touch unavailable	External interference	Check for surrounding interference sources and restart the control box.
		Capacitive touchscreen is effective for finger touch	direct touch with fingers
		Touchscreen problem	Please contact the manufacturer.
4	Temperature display incorrect	The temperature wire is not connected or the wire is not making a good contact.	Connect temperature wires
5	Incorrect air volume display range	The data usage tool you set up is not compatible with the one you installed.	Reset or reinstall the data management tool
6	USB cannot export data	This USB drive is not supported.	Use a USB flash drive that supports the USB 2.0 protocol and FAT file format.
		After plugging in the USB drive, only one data export operation will be performed.	Please unplug and replug the USB drive to export the data again.

Appendix 1 Pipeline Inspection Standards

NO	Standard	Country	Description
1	BS EN 12237 : 2003	EU	Ventilation for buildings—Ductwork—Strength and leakage of circular sheet metal ducts.
2	BS EN 1507 : 2006	EU	Ventilation for buildings—Sheet metal air ducts with rectangular section—Requirements for strength and leakage.
3	DW/143	EU	HVAC—A practical guide to Ductwork leakage testing.
4	Eurovent 2/2	EU	Air leakage rate in sheet metal air distribution systems.
5	SMACNA HVAC Air Duct Leakage Test manual, First edition, 2012	US	Duct construction leakage classification, expected leakage rates for sealed and unsealed ductwork, duct leakage test procedures, recommendations on use of leakage testing, types of test apparatus and test setup and sample leakage analysis.
6	AABC	US	Associated Air Balance Council AABC Standard
7	GB50243 : 2003/2016	GB	Ventilation and Air Conditioning Engineering

1.EU Standards EN12237

Air Tightness Class	Air Leakage Limit (fmax)m³/s/m²	Static Pressure Limit(ps)Pa	
		Negative	Positive
A	$\frac{0.027 \times p_t^{0.65}}{1000}$	500	500
B	$\frac{0.009 \times p_t^{0.65}}{1000}$	750	1000
C	$\frac{0.003 \times p_t^{0.65}}{1000}$	750	2000
D	$\frac{0.001 \times p_t^{0.65}}{1000}$	750	2000

*Class D ductwork is only for special apparatus

2.EU Standards EN1507

Air Tightness Class	Air Leakage Limit(fmax) m³/s/m²	Static Pressure Limit (ps)Pa			
		Negative	Positive at pressure class		
			1	2	3
A	$\frac{0.027 \times p_t^{0.65}}{1000}$	200	400		
B	$\frac{0.009 \times p_t^{0.65}}{1000}$	500	400	1000	2000
C	$\frac{0.003 \times p_t^{0.65}}{1000}$	750	400	1000	2000
D*	$\frac{0.001 \times p_t^{0.65}}{1000}$	750	400	1000	2000

*Class D ductwork is only for special apparatus

3.EU Standards Dw/143

Duct Pressure Class	Static Pressure Limit		Maximum Air Velocity m/s	Air leakage limits l/s/m ²
	Positive Pa	Negative Pa		
Low-pressure-Class A	500	500	10	$0.027 \times P_t^{0.65}$
Medium pressure-Class B	1000	750	20	$0.009 \times P_t^{0.65}$
High pressure-Class C	2000	750	40	$0.003 \times P_t^{0.65}$

4.EU Standards Eurovent 2/2

Air Tightness Class	Air leakage limit(fmax)m ³ /s/m ²
A	$\frac{0.027 \times P_t^{0.65}}{1000}$
B	$\frac{0.009 \times P_t^{0.65}}{1000}$
C	$\frac{0.003 \times P_t^{0.65}}{1000}$

5.US Standards SMACNA

Duct Class	1/2-,1-,2-inwg	3-inwg	4-,6-,10-inwg
Seal Class	C	B	A
Sealing Applicable	Transverse Joints Only	Transverse Joints and Seams	Joints,Seams and All Wall Penetrations
Leakage Class			
Rectangular Metal	16	∞	4
Round Metal	8	4	2

Maximum air leakage is then defined as

$$F = CLP^{0.65}$$

F = Maximum air leakage(cfm/100 ft²)

CL = Leakage class

P = Pressure (inwg)

6.US Standards AABC

No.	Type of System	Minimum Test Pressure	Maximum Allowable Leakage
1	Fractional horsepower fan system;fan coils,small exhaust/supply fans,and residential system	0.50"WC(125Pa)	2%
2	Small systems;split DX systems-usually systems under 2000 CFM(940l/s),and residential systems	1.00"WC(250Pa)	2%
3	VAV and CAV terminal boxes and associated downstream ductwork	1.00"WC(250Pa)	2%
4	Single zone,multi-zone,return ducts,and exhaust duct systems	2.00"WC(500Pa)	2%

5	Chilled-beam primary supply	2.00'WC(500Pa)	1%
6	All ducts in chases and concealed spaces man return ducts on VAV and CAV systems,main ducts on general exhaust or outside air systems	3.00'WC(745Pa)	1%
7	VAV and CAV terminal boxes tested with upstream ductwork	4.00"WC(995Pa)	1%
8	Supply ducts for VAV and CAV systems	4.00'WC(995Pa)	1%
9	Dual duct systems,both hot duct and cold duct	6.00"WC(1495Pa)	1%
10	High pressure induction system	6.00"WC(1495Pa)	0.5%
11	Exhaust systems for labs with air valves	6.00"WC(1495Pa)	0.5%
12	Grease duct Systems	4.00'WC(995Pa)	0.0%
13	Supply,return,and exhaust ductwork located outdoors	3.00'WC(745Pa)	1%

Determine the total allowable leakage of each duct system,including the allowed leakage rate of each component.If the entire duct system cannot be tested,determine the allowed leakage rate in a section of duct. To do this,determine the surface area of the total duct system,and the surface area of each section of the system to be tested.

Tested section air flow rate =Surface area of tested section/Surface area of duct work in entire system ×Total system operating air flow rate

Allowable leakage airflow rate for tested section=Tested section air flow rate ×Allowable percentleakge

7.GB Standard GB50243

Rectangular duct pressure class	Maximum leakage rate m ³ /h/m ²
low voltage system	0.1056×P ^{0.65}
medium voltage system	0.0352×P ^{0.65}
High voltage system	0.0117×P ^{0.65}

P -- refers to the working pressure (Pa) of the duct system.

1. The allowable air leakage of low-pressure and medium-pressure circular metal ducts, composite material ducts, and non-metallic ducts using non-flange construction should be 50% of the specified value for rectangular ducts.

2. The allowable air leakage of brick-concrete ducts should not exceed 1.5 times the specified value for rectangular low-pressure system ducts.

3. Smoke exhaust, dust removal, and low-temperature air supply systems should follow the regulations for medium-pressure system ducts; air conditioning systems of levels 1-5 should follow the regulations for high-pressure system ducts.

Appendix 2 Fan Performance Curves

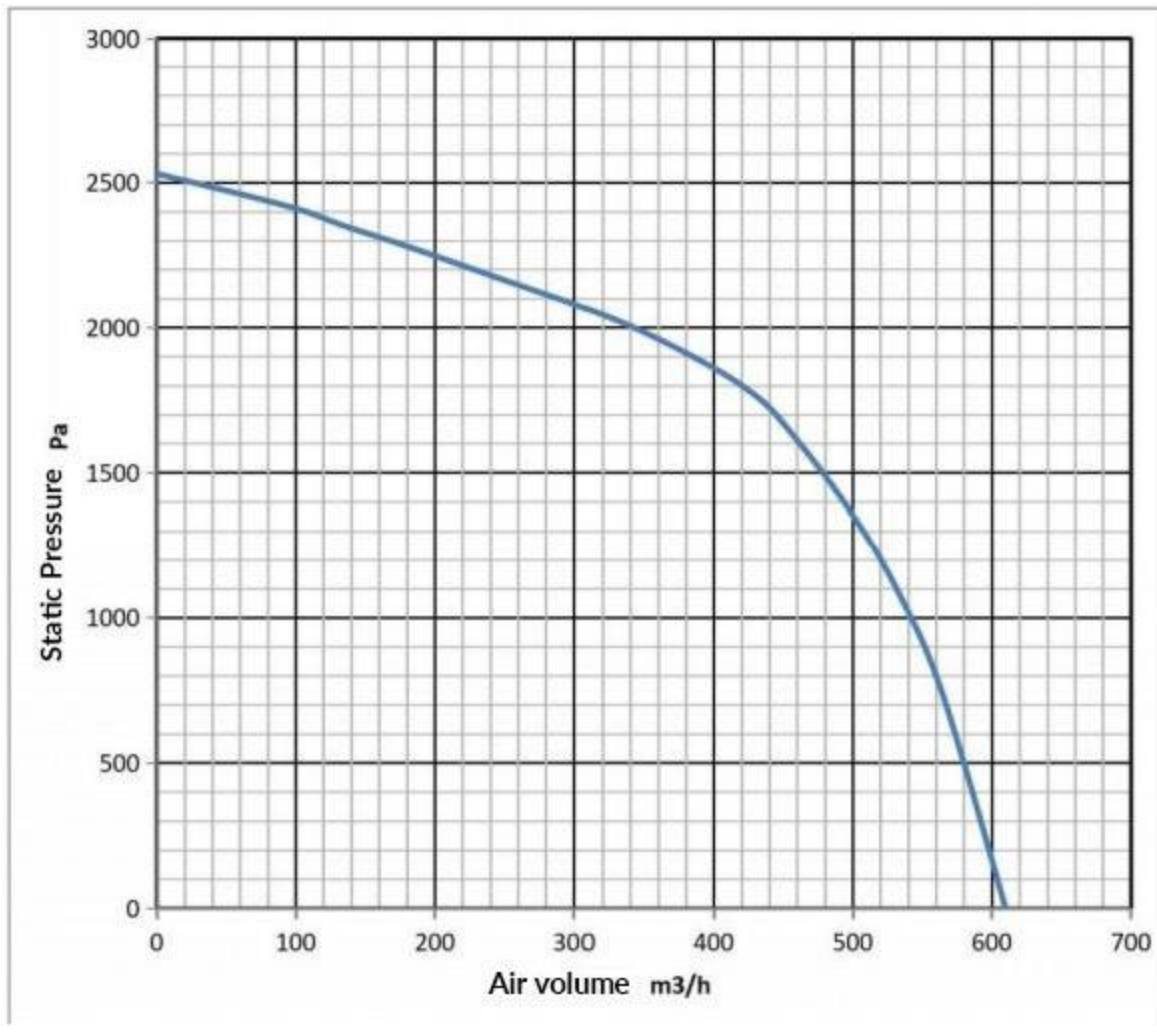

Appendix 3 Installation Diagram

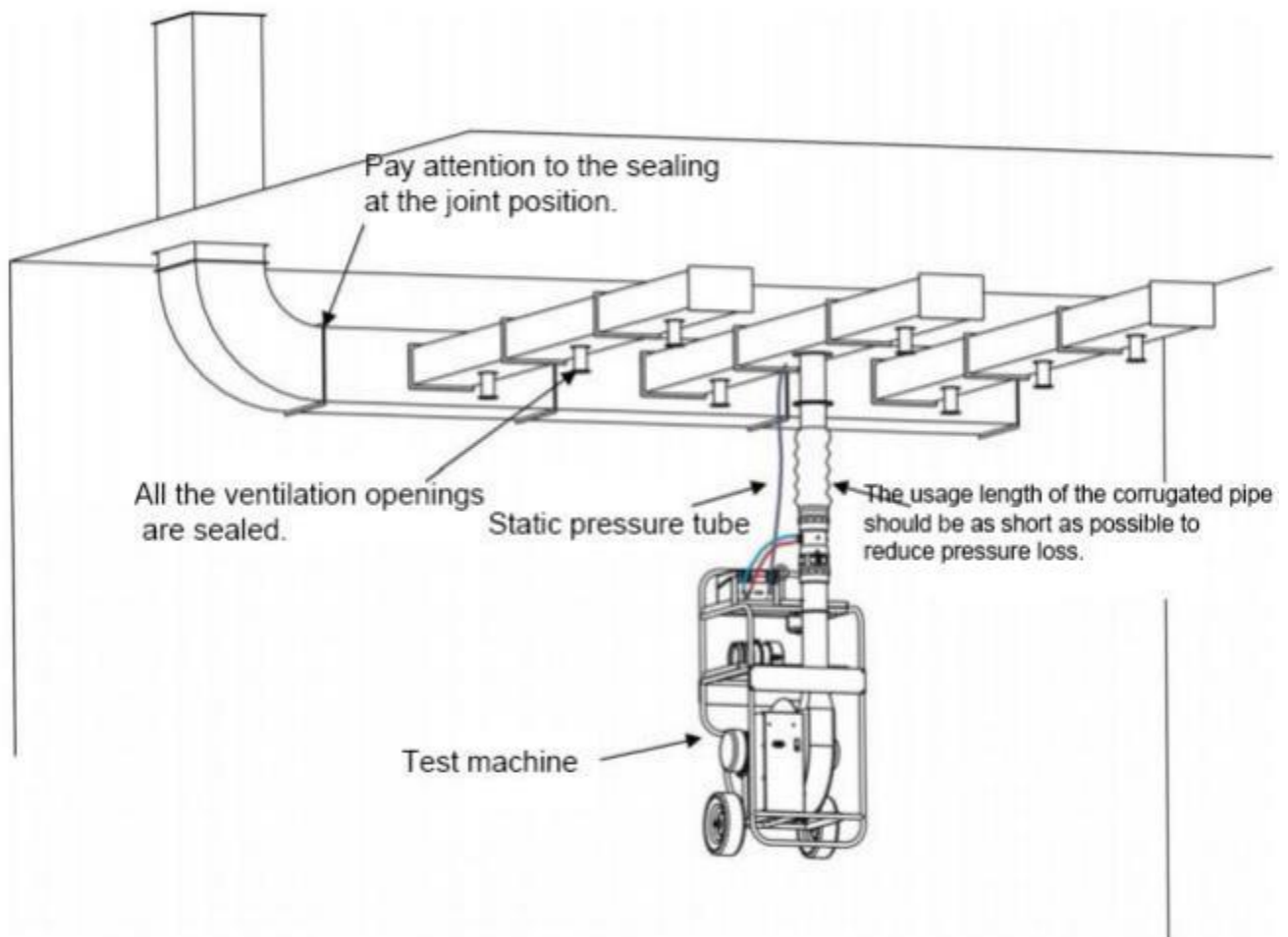

Leak Locator

1. **Visual Inspection:** Observe the seals of all vents and pipe joints.
2. **Listen for noticeable drafts during pressurization;** larger leaks will produce a distinct hissing sound.
3. **Sensing:** Place your hand near the pipe surface; you should feel airflow at the leak.
4. **Soapy Water:** Apply soapy water to the pipe joints and observe for bubbles.
5. **Smoke Pen:** Light a smoke pen and place it inside the pipe; smoke will appear at the leak.